

Experience
Change



Committed to You. Committed to Nature

Committed to Service. At Videocon, service commitment is of utmost priority, which is why our dedication goes beyond the conventional. For us, service is not just about keeping products at their operational best, but also the beginning of a binding relationship. With more than 350 customer care points spread across the country to address your needs, we are just a call away. Our endeavour is to foster a bigger cause by keeping our products Eco-Fit.

VIDEOCON INDUSTRIES LIMITED

Reg. Office: Videocon Industries Ltd., 14 kms. Stone, Aurangabad-Paithan Road, Chitegaon, Tq, Paithan, Dist. Aurangabad-431 105 (India). Phone No.: 02341-251501/02/03/04

Corporate Office: Plot No. 248, Udyog Vihar, Phase - 4, Gurgaon - 122015, Phone No.: 0124-4215400
For more details visit us at www.videoconworld.com. For online shopping visit us at www.edigiworld.com
You could write to us at marketing@vgmail.in. For service issues write to us at customer@vgmail.in or
SMS SVC to 53030

COVER 4

Experience
Change



Owner's manual

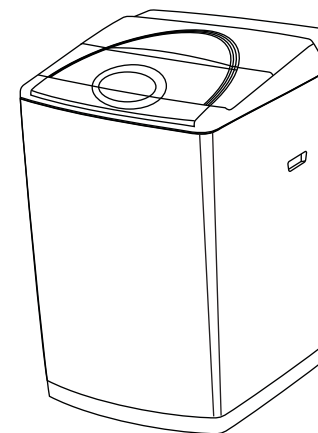

**MODEL:
DIGI NEMO**

FULLY AUTOMATIC WASHING MACHINE

Please read this instruction manual carefully before operating your machine. Retain it for future reference. Record model name & serial number of the machine. Please quote this information when you require service.

COVER 1

CONTENTS

IMPORTANT SAFEGUARDS	2
CARE AND MAINTENANCE	2
ACCESSORIES	3
NAME OF PARTS	3
INSTALLATION INSTRUCTIONS	4-6
NAMES AND FUNCTIONS OF CONTROL PANEL	7-8
NORMAL USAGE	9
HOW TO USE THE CUSTOM COURSE	10
COURSE CHOOSING GUIDE	11
HOW TO USE THE BLANKET COURSE	12
VARIOUS FUNCTIONS	13
HOT-COLD WATER INLET	13
WATER LEVEL SETTING	13
REMEMBER FUNCTION	13
CHILD LOCK FUNCTION	13
TWO CLEAN STEPS FUNCTION	13
TROUBLE SHOOTING GUIDE	14
NO TROUBLE CONDITIONS	14
SPECIFICATIONS	Back Cover

IMPORTANT SAFEGUARDS

⚠ WARNINGS

Never put your hand(s) into the Wash/Spin Tub while the washer is operating.
If you reach into the Wash/Spin Tub, it can cause injury.
If the Wash/Spin Tub dose not stop within 15 seconds after the Washer Lid is opened, turn the washer off immediately and call a service person.



Be sure to connect Power Plug and Power Cord properly.
Be sure to plug the Power Cord into a proper socket-outlet for the washer. An improperly attached plug may catch fire.
Never disconnect by pulling the cord. Hold the plug as you pull it out.
Never use a damaged Power Cord.
Never connect and/or disconnect the Power Plug with wet hands, it may cause an electric shock.

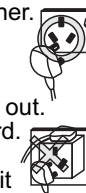

Be sure not to bring any type of flame near the washer or put lit cigarettes or volatile materials on the top of the washer.
It may deform the washer or catch fire, because this washer has a large number of plastic parts.



Never wash items stained with benzine, kerosene, thinner or gasoline.
It may cause a risk of fire or explosion.



Do not install the washer in the bathroom or very humid place.
It may cause a malfunction or an electric shock.



Do not allow children to play on or in the washer.
If a child accidentally falls into the Wash/Spin Tub, serious injury could occur.



Be sure not to splash or pour water on the Control Panel.
It may cause a malfunction or an electric shock.



Do not allow your washer to be repaired by an unqualified service person.
It may cause a risk of accidental fire.
If the washer operates abnormally, it may cause injury.

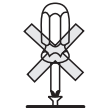

CARE AND MAINTENANCE

Clean washing machine

Use soft clothing to wipe off the water or dirt on the surface of the washer.

- Do not spray water directly to the washer body.
- Detergent, propellant and other chemicals are not allowed to use to avoid the damages on the surface.



Clean the water inlet Valve

(Suggest clean it every 6 months)
After long time use, The water inlet mesh bag may be blocked with crud, please load off the water inlet hose, take out the water inlet mesh bag from the water inlet valve, clean the mesh bag, then assemble the mesh bag in the valve and load the water inlet hose.



Clean lint filter

(Suggest clean it every week)

1. Take out the lint filter.
2. Pull out the scraps and wash the lint filter in the water.
3. Install the Filter (aim the frame claw to the groove below).

(Lint Filer is easily destroyed parts).





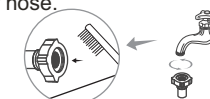

Clean hose filter

(Suggest clean it every 6 months)

1. Turn the nut of water supply hose counterclockwise, take down water hose.
2. clean the crud with a toothbrush.
3. Install the clean water hose.

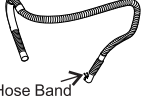

ACCESSORIES

Instruction manual	Drain Hose	Cold water Supply Hose	Hot water Supply Hose	Bottom Cover	Screw
					

NAME OF PARTS

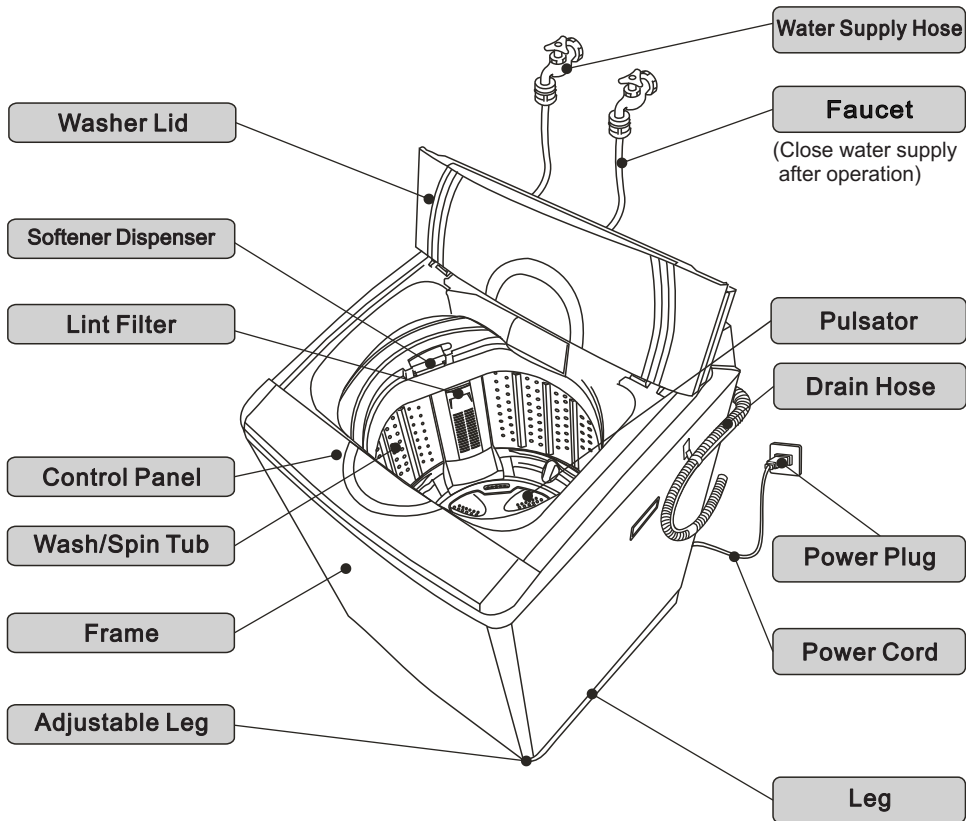

INSTALLATION INSTRUCTIONS

Installing the Bottom Cover

1. Unplug the Power Cord of the washer.
2. Gently lay down the front side of washer on a soft mat or cushion. (Be careful not to dent the Frame.)
3. Insert the attached Bottom Cover into the hooks of Leg by straightly pushing until it reaches into the front hooks.
4. Fasten the Bottom Cover with a screw.
5. Gently set the washer upright.

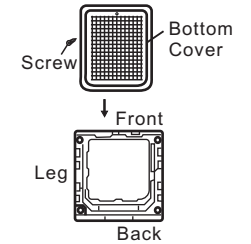

Location of Washer

1. Choose a dry location out of sunlight for the washer.
2. Install the washer on a stable and level surface.



3. Adjust the Adjustable Leg of washer if necessary to make the washer level as shown in the figure.

- The maximum permissible inclination of the supporting surface is 2°.

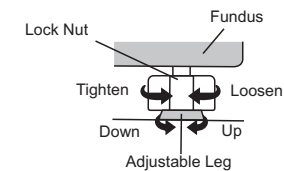

CAUTION:

- Do not block the ventilation openings on the bottom of washer by carpeting when the washer is installed on a carpeted floor.

INSTALLATION INSTRUCTIONS

Connect the Inlet Hose

1. Check that sealing washers are firmly seated.
2. Attach the curved end of the hose to the inlet valve of the washing machine, Tighten the coupling nuts securely by hand.
3. Attach straight end of the hose to the tap. Tighten the coupling nuts securely by hand.
4. Turn on the taps and check for leaks. Tighten the coupling nuts firmly if there is any leakage. If water pressure is strong, close the water tap completely then open it slightly.

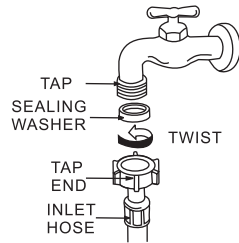

CAUTIONS:

- Do not use water which is hotter than 50°C.
- If your faucet is not suitable, please consult your dealer.

Installing Water Supply Hose to the Washer

Turn the nut clockwise till the nut turned tight while holding the hose.

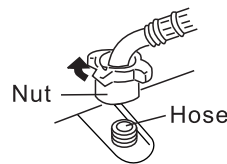

Turn the nut counterclockwise after turning the faucet off when you want to detach the water supply hose.

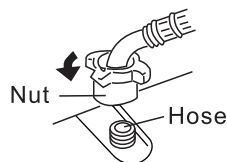

INSTALLATION INSTRUCTIONS

How to Installing the Drain Hose

1. Pinching the two bands of the clamp on the drain hose, connect it to the pump (rear to cabinet) and fix the hose band.
2. Pull the Drain Hose upward and fix it to the hose clip on back over of cabinet.
3. Hang the drain hose to the hole on right side of top frame when the washer is not working. And put the drain hose to drain spout when washer start working.



CAUTION:

1. Please make sure the height of drain hose is not less than 700 mm during operating, otherwise, the washer won't work well, or the water may flow out in the course of washing. And no more than 1000 mm, otherwise the washer will not drain water well.
2. Never lay down the drain hose, as water will discharged.
3. Be sure the drain hose is properly routed so it will not kink or lift from the sink.

Installation Instructions

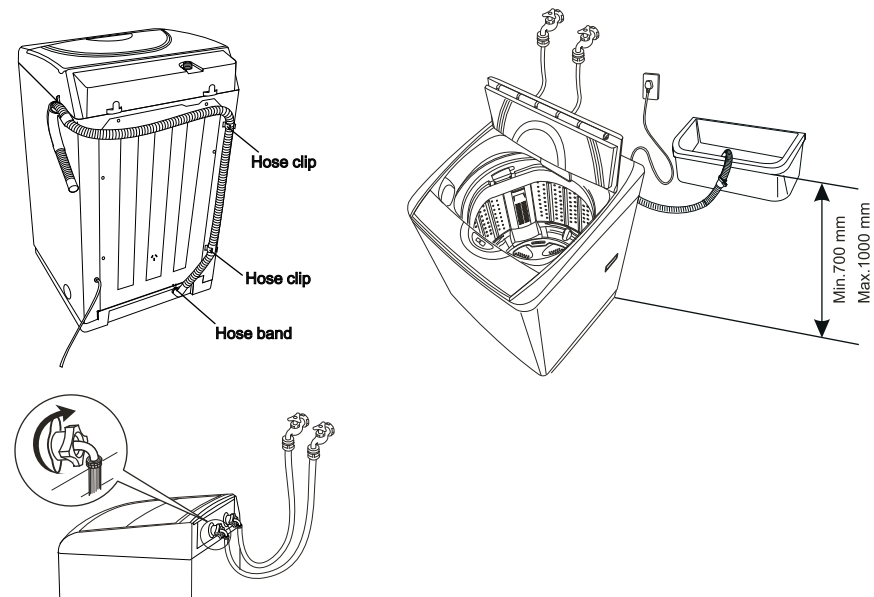

NAMES AND FUNCTIONS OF CONTROL PANEL

DETERGENT Indicators

These are the spoon indications of the DETERGENT volume.

Detailed operation please refer to page 9.



TIMER And PRESET Indicators

• This indicator shows remained time during washing.

(E.g.) Remaining time is 20 minutes

REMAINING TIME **20**

• When setting SELECT, the digital display indicates time or times.

(e.g.) Twice Water Save Rinse

*RINSE **2**

• This indicator shows when the washing is finished during presetting.

(E.g.) Finish washing 2 hours later

*PRESET **2**

• When abnormal conditions occur, the indicator will indicate warning.

(E.g.) Water does not flow

E1

TEMP. Button

Use "temp." button to change water temperature. Light-on means hot water. Light flashes, meaning warm water. And light-off means cold water.

START/PAUSE Button

This button can be used for starting the washer operation. This button can also be used to temporarily stop the washer operation. To restart the washer operation, press the START/PAUSE button again.

NOTES:

This is not a cancel button. If you want to delete the End Buzzer, press the START/PAUSE button and hold down for about 4 seconds until beeping stops. See page 13.

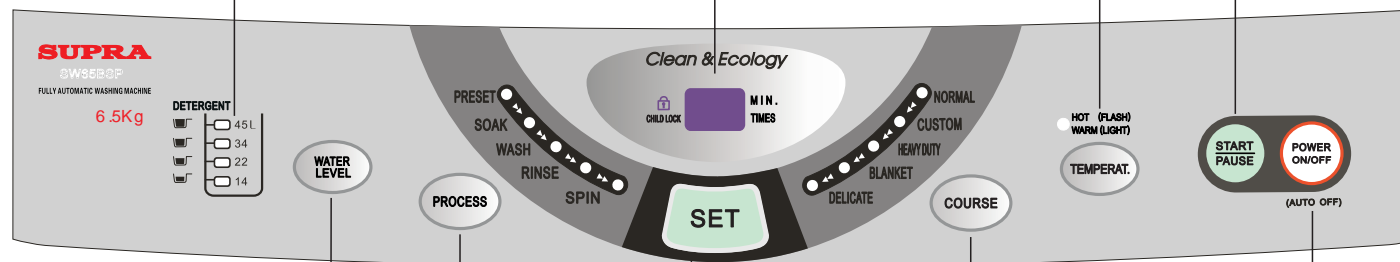

WATER LEVEL Button CHILD LOCK Function

- You can choose the appropriate water level that matches the load size.
- You can set CHILD LOCK function. Refer to CHILD LOCK FUNCTION at page 13.
- Different water levels for washing rinsing optional.

Detailed operation please refer to Page 13.

PROCESS Button And SET Button

- The PROCESS Button can be used to set a variety of wash programs.
- The SET button can be used to set PRESET, SOAK, WASH time, RINSE time and SPIN time. Detailed operation please refer to Page 10.
- Press "SET" button to adjust water power during washing or rinsing. Detailed operation please refer to Page 13.
- Water power function could not be set for DELICATE or BLANKET course.

COURSE Button

To choose the washing course, press COURSE button.

NOTE:

If you choose the NORMAL, HEAVY DUTY, CUSTOM course, the washer will automatically begin the NEURO & FUZZY operation.

POWER ON/OFF Button

To turn the power on, press the POWER ON/OFF. When you want to turn off the power, press the POWER ON/OFF button again. When washing has finished, the power will be turned off in 5 seconds automatically.

NOTES:

- If you want to change the wash program, press the POWER ON/OFF button and then on it again.
- If you leave the washer turning on without starting the operation, the power will be turned off in 10 minutes by itself.

NORMAL USAGE

Procedure

Connect the Drain Hose. Connect the Water Supply Hose to the faucet and turn the faucet on. Plug the Power Cord into a socket-outlet. Load the laundry into the washer. Make sure that screws of "Magic" Hose Joint are tighten before opening the faucet. If screws are loose, it may cause water to leak.

1. Press the POWER ON/OFF button.
2. Press the START/PAUSE button.
Sensor tests the clothes weight automatically. (For NORMAL, HEAVY DUTY, CUSTOM). Auto choose the proper Water Power, Water Level, Wash and spin time, rinse type.
3. Use recommended amount of detergent as shown in chart.

DETERGENT AND LOAD RECOMMENDATIONS				
Water Level				
Water Volume (Approx. L)	14 L	22 L	34 L	45 L
Detergent Indicators				
Powdered detergent volume (g)	12~20	20~28	28~36	36~50
Other detergent volume	You may adjust the detergent volume according to the type of detergent-follow recommendations on package.			

- You can use softener, pour the softener slowly to Softener Dispenser before washing.
 - Too much detergent causes poor rinsing and too little detergent causes poor washing.
4. Close the washer lid.
- The washer will alarm and stop working before spinning if the washer lid is not closed.

HOW TO USE THE CUSTOM COURSE

Procedure

1. Press POWER ON/OFF button .
2. Press COURSE button to Select the course you want.
3. Press the PROCESS button to select the process and time .
Press PROCESS button choose your like cycle.
The light moves right one by one when press.

• SOAK time indicating	0-5 40 ... 35-40 → Min. (This function is not available for DELICATE/ BLANKET course).
• WASH time indicating	0-1 2 ... 19-20 → Min.
• RINSE times indicating	0-1 2 3 → Min. (The number means times).
• SPIN time indicating	0-1 2 ... 8 9 → Min. (Except the DELICATE course).
	0-1 2 3 → Min. (For DELICATE course).

4. Press WATER LEVEL button, choose proper water level .
Putting detergents.
5. Close the washer lid.
6. Press the START/PAUSE button.
At the end of working the buzzer will sound
The CUSTOM course could be remembered.

COURSE CHOOSING GUIDE

COURSE	Water Power	Suitable Clothes
NORMAL	Standard	Normal clothes
HEAVY DUTY	Strong	Dirty Clothes like working coat
CUSTOM	Standard	Kinds of clothes
DELICATE	Soft	Women underwear, articles with embroider
BLANKET	Blanket	Blanket or Bulky
DETERGENT FREE	Standard	Lightly duty clothes

COURSE CHOOSING GUIDE

COURSE	WASH POWER	SUITABLE CLOTHE	OPERATION STATUS FOR THE PROGRAM		
			WASHING TIME(min.)	RINSING TYPE	SPINING TIME(min.)
NORMAL	Standard	Normal clothes	6~12	Water Saver Rinse 2 times	5~6
CUSTOM	Standard	Kinds of clothes	Soak10 + Wash10	Water Saver Rinse 2 times	5
HEAVY DUTY	Strong	Dirty clothes like working coat	8~14	Water saver Rinse 2 times	7~8
BLANKET	Blanket	Blanket or Bulky	12	Water saver Rinse 2 times	8
DELICATE	Soft	Women underwear, articles with embroider	6	Water Saver Rinse 2 times	2

- Possible the total time is not same due to different water pressure.
- Shower rinse could be changed as Water Saver Rinse . Please see Page 2 instructions SHOWER RINSE. 

THE PREPARATION OF LAUNDRY BEFORE WASHING

- Make sure that nothing remained in pocket. (Pin, coin or something like possibly damage clothes or washing machine, and the extra noise occurred may cause trouble to washing machine).
- Overturn the clothes to get rid of scraps.
- Wool items like women underwear, articles with embroider, nylon etc, should be placed in a laundry net for extra protection.
- Close the fastener and tie loose laces.
- Brush the dirty parts like dust, sand.
- Put light clothes down. Please pause operation and push it into water when it floats up.
- Please separate washing white clothes from coloured clothes, coats from underwear.

HOW TO USE THE BLANKET COURSE

For washing blanket and other bulky items.

The water level will be changed to 4 automatically when BLANKET course set. While you can adjust it from level 3 to level 4 by hand according to the blanket or the bulky items size.

Procedure

1. Press POWER ON/OFF button and open the washer lid.
2. Press COURSE button continuously and choose the BLANKET course (The BLANKET Light flashes).
3. After the detergent is dissolved with proper amount of warm water (approx. 30), pour it into the tub of the washing machine.
4. Fold up the blanket as the method showed in the figures below and put it into the washing tub.
5. Press the START/PAUSE button.
6. Close the washer lid.

The washer will stop working automatically before spinning if the washer lid is not closed.

The buzzer will alarm at the end of operation and the power will be switched off automatically in 5 seconds.

Then please shut water supply and clean the filter.

How to fold up the blanket and put it into the washing tub.

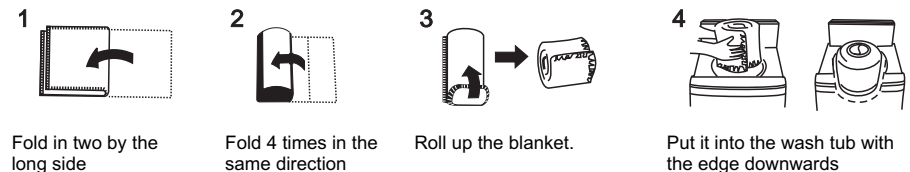

Wash Finish

Take out blanket and hang it up.

NOTICE:

Clean the dirty side by hand firstly.

Use proper volume detergent.

It is better to clean dirty by warm water (approx. 30•).

If the blanket floats out during washing, please press START/PAUSE button, the washer will stop working temporarily. Then, please push the blanket down, and press START/PAUSE again to continue washing.



VARIOUS FUNCTIONS

HOT-COLD WATER INLET

Selection into the hot water, cold water and warm water. Press the TEMP button.

Method of setting

Press POWER ON/OFF button to switch on the power, and press TEMP button to choose.

If the light is flash. It is into the hot water.

If the light is light. It is into the warm water.

If the light is not flash. It is into the cold water.

WATER LEVEL SETTING

Washing with low level water and rinsing with high level water will help more clean washing and completely rinsing.

Method of setting

Press WASH button to set wash time, press WATER LEVEL button to set water level for wash, press RINSE button to set rinse type and rinse times. Then press WATER LEVEL to set water level for rinse, press SPIN button to set spin time, press START/PAUSE button to start. By this, wash and rinse will work according to the water levels set separately.

REMEMBER FUNCTION

When select NORMAL, CUSTOM or HEAVY DUTY, 15 seconds after starting, the machine will remember this program and starts same next time working.

- This function is not available for DELICATE/BLANKET course.
- PRESET and WATER LEVEL will not be remembered.
- The Soak, Wash, Rinse and Spin for CUSTOM program could be remembered.

CHILD LOCK FUNCTION

The Washer will stop working automatically and alarm if washer lid opened 5 seconds during oper

Method of setting

Press POWER ON/OFF button to switch on the power, and press COURSE button for 4 seconds till a sound from buzzer. To restore it, repeat above .

When setting child lock, all the button on control are locked and can't be operated until relive child lock.

TWO CLEAN STEPS FUNCTION

The washer will start washing when water to the level below 2 levels as set. By this, the washer starts working with more density of detergent.

This function won't be effected when select level 1 or level 2 water, and DELICATE or BLANKET course.

When SOAK is selected, this function will not be effected after soaking.

TROUBLE SHOOTING GUIDE

Trouble Indication

When the following problems occur, the microcomputer will detect the abnormal condition and an electronic buzzer sounds for approximately 10 seconds and the indicators flash as shown below. At the same time, the washer stops operation.

Kind of Trouble	Trouble Indication	Where to Check
The washer does not work at all.		Press the POWER ON/OFF button. Press the START/PAUSE button. Press the PRESET button. Check whether power failure occurs. Check whether the fuse or circuit breaker has been activated.
Water does not flow into the Wash/Spin Tub.	E1	Turn the water supply faucet on. Check whether the water supply has been cut off. Check whether the metal filter of the Water Inlet is clogged. Check the washer has been freezing. Check whether water pressure is too low.
Water does not drain out.	E2	Put down the Drain Hose from the hookhole. Check the Drain Hose for any obstructions. Check whether the Drain Hose is clogged. Check whether the Drain Hose rises too high off the ground.
The washer does not spin.	E3	Check whether the laundry is clumped on one side of the Wash/Spin Tub. Check whether the washer is on the level surface.
	E4	Close the Washer Lid.
The buzzer keeps beeping.	E5	Check whether the CHILD LOCK is set. Close the Washer Lid.
Other troubles.	E A E C	Press the POWER ON/OFF button to turn off the power, call your service-person or dealer.

NOTE: The trouble indicators can be released by pressing the START/PAUSE button once if you want to release the emergency stop.

Then press the START/PAUSE button again to restart the operation.

NO TROUBLE CONDITIONS

1. During Washing or Rinsing, still there is Water inletting. This is possibly automatic water adding due to water level decrease.
2. Spin tub turns or stops timely at the beginning of spinning. This is intermittent spinning for better spin effect.
3. Water inletting and rinsing sometimes during spinning. This is automatic lean-correction due to clothe is not equally inside.
4. There is sound like water flow after spinning. This is the sound of balance liquid in Balance ring. It is for reducing vibration of spinning.
5. Control panel keeps warm after power off, this is caused by Remembering circuitry working.
6. Power off during working and the washer could not continue working. Should set the program again.

SPECIFICATIONS

Dimensions	555(W) x 575(D) x 950(H) mm
Weight	35 kg
Water quantity (HIGH)	45 litres
Power Source	AC Local voltage
Power Consumption	340 W
Required Water Pressure	0.03 Mpa ~ 0.8 MPa (0.3 kgf/cm ² ~ 8 kgf/cm ²)

FOR WASHER WITH A 10 Amp. PLUG TOP 3 PIN

WARNING - This appliance must be earthed.



IMPORTANT

The wires in this mains lead are coloured in accordance with the following code:

Green/yellow: Earth
Blue: Neutral
Brown: Live

As the colours of the wires in the mains lead of this appliance may not correspond with the coloured markings identifying the terminals in your plug, proceed as follows:

The wire which is coloured green and yellow must be connected to the terminal in the plug which is marked with the letter E or by the earth symbol , or coloured green or green and yellow.

The wire which is coloured blue must be connected to the terminal which is marked with the letter N or coloured black.

The wire which is coloured brown must be connected to the terminal which is marked with the letter L or coloured red.

AUTHORISED SERVICE CENTER

Branch Network

NORTH ZONE

DELHI: 011-39996369 GURGAON: 0124-4201250/54 CHANDIGARH: 0172-5074588
JAIPUR: 0141-4085010 KARNAL: 9254304822 LUDHIANA: 0161 5032738/39/740/741
AGRA: 0562-3201515 LUCKNOW: 0522-4017315 DEHRADUN: 0135-3248805
JODHPUR: 0141-3268934, 3248934 JALANDHAR: 0181-5020297 VARANASI: 0542-2363383
JAMMU: 0191-2431759 GHAZIABAD: 0120-4162000

SOUTH ZONE

CHENNAI: 044-26209378/2629379 BANGALORE: 080-32941177/66/44
COCHIN: 0484-3113155/66/77 HYDERABAD: 040-32449623, 32446200
COIMBATORE: 0422-2333146 MADURAI: 0452-3268866/27 VIJAYAWADA: 0866-3248833/55
VIZAG: 0891-2732037 HUBLI: 0836-3246644/55, 4250971
MANGALORE: 0824-2491388 CALICUT: 0495 - 3233511/22 WARANGAL: 0870- 3293300/11

EAST ZONE

KOLKATA: 033-44031400 BHUBANESHWAR: 0674-2597281 RANCHI: 0651-2340362
ASANSOL: 0341-2221017 GUWAHATI: 9954746944 PATNA: 0612-6457897

WEST ZONE

AHMEDABAD: 079-26400418/26408976 AURANGABAD: 0240-2471201
BHOPAL: 0755-3206631 BARODA: 0265-2359084/3249443 SURAT: 0261-2461569
RAJKOT: 0281-2465041 GOA: 0832-2462554 RAIPUR: 0771-2445196 THANE: 022-32162709
PUNE: 020-24260329/489 INDORE: 0731-2544537 MUMBAI: 022-40584600
NAGPUR-AKOLA: 0712-2543079 JABALPUR: 0761-3221556 NASHIK: 0253-2582703/704

WARRANTY TERMS AND CONDITIONS

FILL AND DESPATCH WARRANTY CARD ELSE THE WARRANTY VOIDS

VIDEOCON warrants to the purchaser of this Videocon Washing Machine that for a period of 24 months, commencing from the date of purchase, the company will repair or replace free of charge any part or parts of the Washing Machine except Top Lids, Inlet/Drain Hose and lint Filter, should the company be fully satisfied, in its sole discretion, that the defect/s is/are due to faulty material or workmanship only. The warranty will be governed by the following clauses :

1. This warranty is confined to the original products of the company only.
2. The company or their authorised service Agent / will repair / replace all parts failing due to faulty material or defective workmanship pertaining to the above Washing Machine.
3. Only the company or its authorised Service Agent / can service/repair/attend to install/reinstall the washing Machine. The list of Company's service centre is as printed overleaf.
4. If the machine is not repairable at the place of its installation then the decision of technician to call back the machine to Service Centre for repairs shall be final. In such cases it is the responsibility of Purchaser to bring the machine to the Service Centre.
5. For the units installed beyond the municipal limits of the jurisdiction of the authorised service a Company's authorized service station or the dealers of VIDEOCON as well as expenses incurred in connection with deputing of service personnel/technicians towards to and fro travel conveyance with deputing of service incidentals etc. will be borne by the customer.
6. Any change of location of the unit and / or change of ownership has to be done in consultation with VIDEOCON or its authorised service agent so that the warranty obligation for the remaining part of the warranty could be transferred to the new owners or the original purchaser but at the new location. The unit so transferred will be inspected by VIDEOCON or its service agent at the cost inspection charges.
7. Any damage caused during shifting will be repaired on chargeable basis. In the event of repair / replacement of any part/s of the set, this warranty will thereafter, continue and remain in force only for the unexpired period as per the warranty card issued at the time of purchase of the set. Moreover, the time taken for repair and in transit, whether under the warranty or otherwise, shall not be excluded from the warranty period.
8. This warranty will continue to be in force for the term herein specified, irrespective of what replaced may be provided under it, and such replacement shall not attract any fresh warranty unless specified.
9. The warranty extended herein is in lieu of all implied conditions and warranties under the law and is confined to the repair or replacement of defective parts and does not cover any consequential or resulting liability, damage or loss arising from such defects. Furthermore, the warranty in no case, shall extend to the payment or any monetary consideration whatsoever of the replacement or return of the Washing Machine as a whole.
10. The defective spare part/s shall be the sole property of company and will be collected by the Authorised Service Centre / Franchisee.
11. It shall be the discretion of the company to replace the required part with suitable and currently available part/s. The company may also use the substitute part for defective part.

WARRANTY TERMS AND CONDITIONS

12. The warranty does not cover any accessories external to the system or supplied by dealer.
13. The company's obligation under this warranty shall be limited to repairing or providing replacement of parts, which are found to be defective within warranty period.
14. Any defects in electrical installation on fittings outside Washing Machine shall have to be rectified by the purchaser only.
15. The company shall not be liable for any delay in rectifying the machine, in the event of non-availability of components and shall in no way be responsible for any losses, direct or indirect, arising out of the delay, if any.
16. If the machine is inspected by the authorized service center during warranty period and product is found free from any sort of damage/defect, Applicable visiting charges will be payable by customer.
17. Warranty shall stand ceased / cancelled if the machine is used for any type of commercial purpose.
18. The company is not responsible for any breakage or non - performance or delay in providing service due to strike, industrial/labour dispute, fire, accident, damage, restriction imposed by Government, Act of God, riot, war, etc. which are beyond the control of the company.
19. The warranty is issued subject to the jurisdiction of Aurangabad Court of law.
20. If any colored internal or external components are replaced there will be commitment to ensure that shades match with the original or other components. The replaced shades, patterns, tints may vary from the customer's unit due to continuous usage of unit. Any matching components changed at customer's request will be on chargeable basis except the component which are actually needed.

THIS WARRANTY IS NOT APPLICABLE IN ANY OF THE FOLLOWING CASES

1. The warranty card is not duly filled and mailed back to the service centre for registration by the purchaser, within 10 days of purchase.
2. The completed Warranty card is not presented to the company technician at the time of repair.
3. The machine is not used according to the instruction given in owner's guide.
4. Defects caused by improper use as determined by the company personnel.
5. Any repair work/installation is carried out by the person other than Videocon service centre/service agent.
6. Site (premises where the product is kept) conditions that do not conform to the recommended operating conditions of the machine.
7. The serial number is deleted, defaced or altered.
8. If the electrical power supply voltages, are not within the stipulated norms.
9. Any defects arising out of lightning, abnormal voltage, fire, accident, any acts of God or other circumstances beyond the control of the company while the machine is in transit or otherwise.
10. Defects caused by household pets, Rats, Cockroaches or any other animals or insects.

For any doubts or clarifications please contact us on-

TEKCARE INDIA PRIVATE LIMITED.,

15km. STONE, AURANGABAD-PAITHAN ROAD,

VILLAGE CHITEGAON, TALUKA PAITHAN,

AURANGABAD - 431 105,

MAHARASHTRA, INDIA.

PHONE No. - 02431 - 329271,329783

E MAIL : customercare@vgmail.in

Web : www.servicedelight.com

CUSTOMER COPY

Customer Name : _____ Customer Address : _____ _____	Service Registration at - _____ _____
Tel No. : _____ _____	
Dealer Name : _____ Dealer Address : _____ _____	Dealer Bill Date : _____ Bill No. : _____ Set Serial No. : _____
Tel No. : _____ Model No. : _____ DOP : _____ I accept the terms and conditions of warranty.	
Dealer sign & seal	Customer sign

CUT HERE

SERVICE CENTER COPY

Customer Name : _____ Customer Address : _____ _____	Service Registration at - _____ _____
Tel No. : _____ _____	
Dealer Name : _____ Dealer Address : _____ _____	Dealer Bill Date : _____ Bill No. : _____ Set Serial No. : _____
Tel No. : _____ Model No. : _____ DOP : _____ I accept the terms and conditions of warranty.	
Dealer sign & seal	Customer sign

CUT HERE

CSO AURANGABAD COPY

Customer Name : _____ Customer Address : _____ _____	Service Registration at - _____ _____
Tel No. : _____ _____	
Dealer Name : _____ Dealer Address : _____ _____	Dealer Bill Date : _____ Bill No. : _____ Set Serial No. : _____
Tel No. : _____ Model No. : _____ DOP : _____ I accept the terms and conditions of warranty.	
Dealer sign & seal	Customer sign
This card stands null and void if the Service Center copy of Warranty Card is not dispatched within 10 days of date of purchase (DOP) and duly signed by Authorized Dealer on date of purchase.	

Note : The after sale service shall be subject to the production of this card at the time of each servicing, either at the place of the customer or at any service center. In absence of this card, the company shall not be liable to provide after sale service as per the warranty norms.

SERVICE

1800 419 40 40
Landline/Mobile-Toll Free

39 40 40 40

Prefix the STD code of the state capital

SMS - 'SVC' to 53030

Keeping products Eco-Fit

IN CASE OF CONSUMER COMPLAINTS, PLEASE CONTACT :
M/s TEKCARE INDIA PRIVATE LIMITED, 15 Km STONE, AURANGABAD
PAITHAN ROAD, VILLAGE CHITEGAON, TALUKA PAITHAN,
DIST-AURANGABAD. - 431105, MAHARASHTRA, INDIA PH. NO.(02431) 329271,329783
E-MAIL: customercare@vgmail.in, WEBSITE: www.servicedelight.com
GET REGISTERED BY SENDING SMS -'SVC' TO 53030

BUSINESS REPLY CARD

To,

AFFIX
PROPER
POSTAGE
HERE

BUSINESS REPLY CARD

To,

M/s. TEKCARE INDIA PRIVATE LIMITED.,
15km. STONE, AURANGABAD-PAITHAN ROAD,
VILLAGE CHITEGAON, TALUKA PAITHAN,
AURANGABAD - 431 105,
MAHARASHTRA, INDIA.
PHONE No. : (02431) - 329271,329783

AFFIX
PROPER
POSTAGE
HERE

COMMISSIONING REPORT



Sale Date - Model

Sr. No.

Dealer's Stamp

Service Engineer Mr.

- 1. PackingOK / DAMAGED
- 2. AccessoriesOK / MISSING / PART RECIEPT
- 3. Controls / Operations ExplainedYES / NO
- 4. DemonstrationGIVEN / NOT GIVEN
- 5. PerformanceOK / NOT OK
- 6. AppearanceOK / NOT OK
- 7. Noise LevelNORMAL / MORE

Customer's Signature
And Postal Address

SERVICE ENGINEER'S SIGN.

CUT HERE

Front

Location of Machine at customer's site

Earthing Ensured / Not Ensured

- Free from high humidityYES / NO
- Free from direct water sprayYES / NO
- Exposed to Direct sunlightYES / NO
- Drain hose connectedYES / NO

PLEASE POST THIS CARD IMMEDIATELY
TO DOUBLE ENSURE THE SERVICE

USE THREE PIN SOCKET ONLY
240V / 50HZ

M/s

TEKCARE INDIA PRIVATE LIMITED,
15 km. STONE, AURANGABAD - PAITHAN ROAD,
VILLAGE CHITEGAON, TALUKA - PAITHAN,
AURANGABAD - 431 105
MAHARASHTRA, INDIA

Affix
Postage
Stamp

CUT HERE

Back